

## Silicon PNP RF Transistor

### Applications

UHF/VHF uncontrolled prestages with low noise and low modulation

### Features

- High cross modulation performance
- High power gain
- Low noise
- High reverse attenuation

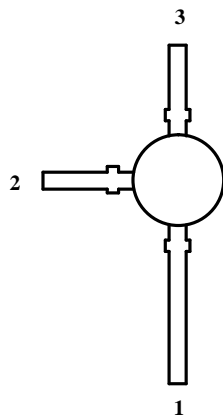

BF979 Marking

Plastic case (~TO 50)

1= Collector; 2= Base; 3= Emitter

### Absolute Maximum Ratings

Parameters	Symbol	Value	Unit
Collector-base voltage	$-V_{CBO}$	20	V
Collector-emitter voltage	$-V_{CEO}$	20	V
Emitter-base voltage	$-V_{EBO}$	3	V
Collector current	$-I_C$	50	mA
Base current	$-I_B$	5	mA
Total power dissipation $T_{amb} = 25\text{ }^\circ\text{C}$	$P_{tot}$	550	mW
Junction temperature	$T_j$	150	$^\circ\text{C}$
Storage temperature range	$T_{stg}$	-55 to +150	$^\circ\text{C}$

### Maximum Thermal Resistance

Parameters	Symbol	Value	Unit
Junction ambient	$R_{thJA}$	225	K/W

### Electrical DC Characteristics

$T_{amb} = 25\text{ °C}$ , unless otherwise specified

Parameters / Test Conditions	Symbol	Min.	Typ.	Max.	Unit
Collector cut-off current $V_{CB} = 15\text{ V}$	$-I_{CBO}$			100	nA
Collector-base breakdown voltage $-I_C = 10\text{ }\mu\text{A}$	$-V_{(BR)CBO}$	20			V
Collector-emitter breakdown voltage $-I_C = 2\text{ mA}$	$-V_{(BR)CEO}$	20			V
Emitter-base breakdown voltage $-I_E = 10\text{ }\mu\text{A}$	$-V_{(BR)EBO}$	3			V
DC forward current transfer ratio $-V_{CB} = 10\text{ V}, -I_C = 10\text{ mA}$	$h_{FE}$	20	50		

### Electrical AC Characteristics

$T_{amb} = 25\text{ °C}$

Parameters / Test Conditions	Symbol	Min.	Typ.	Max.	Unit
Gain bandwidth product $-V_{CB} = 10\text{ V}, -I_E = 10\text{ mA}, f = 300\text{ MHz}$ $-V_{CB} = 10\text{ V}, -I_E = 30\text{ mA}, f = 300\text{ MHz}$	$f_T$ $f_T$		1750 1300		MHz MHz
Collector-base capacitance $-V_{CB} = 10\text{ V}, f = 100\text{ MHz}$	$C_{CB}$		0.6		pF
Noise figure $-V_{CB} = 10\text{ V}, -I_C = 10\text{ mA}, R_G = 50\text{ }\Omega, f = 800\text{ MHz}$	$F_b$		3.4	4.2	dB
Power gain $-V_{CB} = 10\text{ V}, -I_C = 10\text{ mA}, f = 800\text{ MHz},$ $R_G = 50\text{ }\Omega, R_L = 500\text{ }\Omega,$	$G_{pb}$	16	16		dB
Collector current for $G_{pbmax}$ $-V_{CB} = 10\text{ V}, f = 800\text{ MHz}, Z_L = 500\text{ }\Omega$	$I_C$		10		mA

## Dimensions in mm

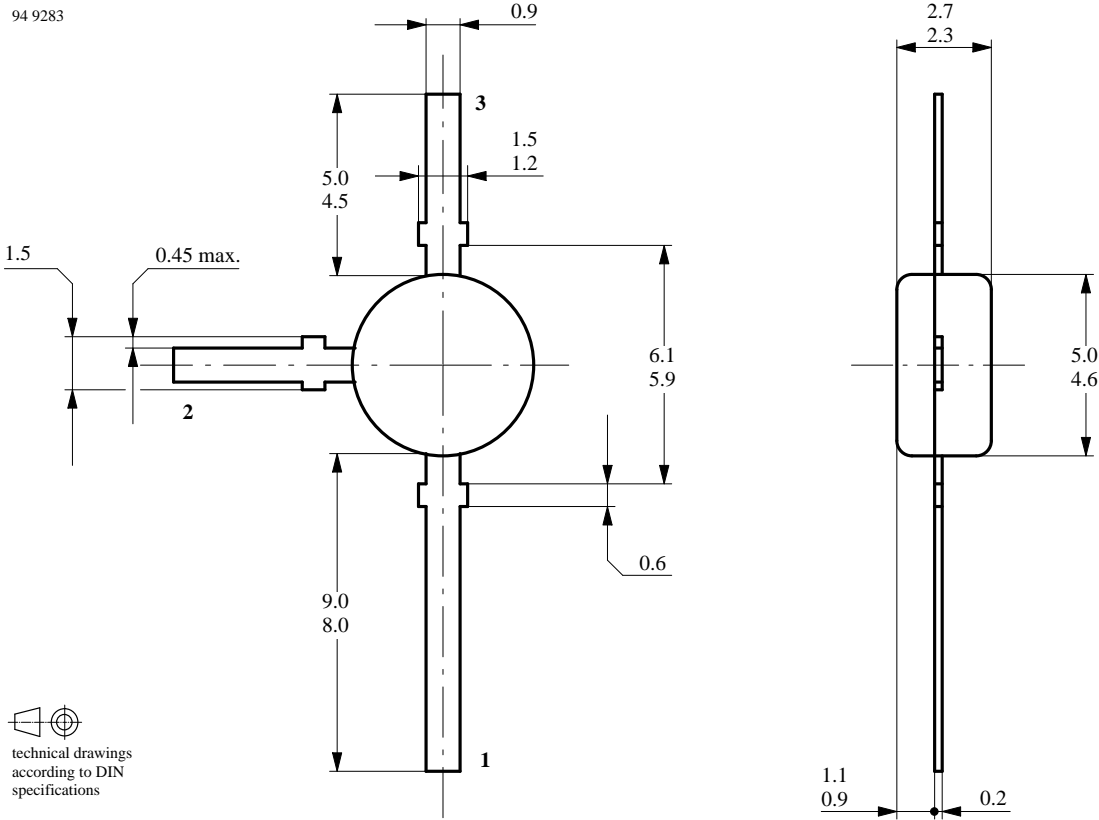

### Ozone Depleting Substances Policy Statement

It is the policy of **TEMIC TELEFUNKEN microelectronic GmbH** to

1. Meet all present and future national and international statutory requirements.
2. Regularly and continuously improve the performance of our products, processes, distribution and operating systems with respect to their impact on the health and safety of our employees and the public, as well as their impact on the environment.

It is particular concern to control or eliminate releases of those substances into the atmosphere which are known as ozone depleting substances (ODSs).

The Montreal Protocol (1987) and its London Amendments (1990) intend to severely restrict the use of ODSs and forbid their use within the next ten years. Various national and international initiatives are pressing for an earlier ban on these substances.

**TEMIC TELEFUNKEN microelectronic GmbH** semiconductor division has been able to use its policy of continuous improvements to eliminate the use of ODSs listed in the following documents.

1. Annex A, B and list of transitional substances of the Montreal Protocol and the London Amendments respectively
2. Class I and II ozone depleting substances in the Clean Air Act Amendments of 1990 by the Environmental Protection Agency (EPA) in the USA
3. Council Decision 88/540/EEC and 91/690/EEC Annex A, B and C (transitional substances) respectively.

**TEMIC** can certify that our semiconductors are not manufactured with ozone depleting substances and do not contain such substances.

**We reserve the right to make changes without further notice to improve technical design.**

Parameters can vary in different applications. All operating parameters must be validated for each customer application by customer. Should Buyer use TEMIC products for any unintended or unauthorized application, Buyer shall indemnify TEMIC against all claims, costs, damages, and expenses, arising out of, directly or indirectly, any claim of personal damage, injury or death associated with such unintended or unauthorized use.

TEMIC TELEFUNKEN microelectronic GmbH, P.O.B. 3535, D-74025 Heilbronn, Germany  
Telephone: 49 (0)7131 67 2831, Fax Number: 49 (0)7131 67 2423